



FITTING INSTRUCTIONS

Product:

AIRTEC SNORKEL

Vehicle:

MY 22 FORD RANGER

Part No.

011SAT0121Y 011SATW0121Y

- Before commencing installation of this product- Please read the Fitting instructions carefully, ensure that the Air Box configuration is the same as the images shown in these instructions
- Check all listed components are supplied in the kit.
- **DO NOT USE THIS PRODUCT AS A HAND HOLD TO ENTER THE VEHICLE**
- Left-Hand and Right-Hand components are determined as seated in the vehicle looking forward
- Always place the product on a flat level bench or surface, cover with a soft cloth or blanket to prevent damage to parts prior to installation.
- When removing protective coatings, ensure all new edges are deburred, clean any swarf from the area and apply rust preventative product to exposed painted surfaces where applicable.
- To provide adequate sealing of the snorkel system all joints and openings must be sealed using neutral cure silicone.
- **IMPORTANT:-** The drain hole as fitted to this vehicles Air Box must be able to drain freely. TJM recommends frequent inspection to confirm that the Air Box Drain is not retaining water or Blocked – Especially after water crossings. It is common to find water in the base of the Air Box particularly when driving during torrential rain and / or inclement weather. **WARNING:-** failure to keep the Air Box Drain free of Debris may result in the vehicle going into “Limp” mode.
- The fitment of this TJM products does not nullify the OE manufacturer’s operating guidelines and / or warnings. Ensure you are familiar with and adhere to the usage instructions specified by the manufacturer in the owner’s manual or other official documentation.
- Tools needed for installation of this product:- Metric Socket and Spanner Set, Screwdriver Set, Electric Drill, Metric Drill Bit Set, Stepped Drill, Ø 121 Hole Saw, Ø 89 Hole Saw, Hammer & Centre Punch, Soft Face Hammer, Masking / protective tape, Tube of Neutral cure silicone and Loctite or similar product, Rust preventive product or similar.

If you buy from 4x4AT, we offer fitting services at an additional cost. Please contact us for more information.



FITTING INSTRUCTIONS

Product:	AIRTEC SNORKEL
Vehicle:	MY 22 FORD RANGER
Part No.	011SAT0121Y 011SATW0121Y

- PPE including safety glasses, Hearing protection and gloves should be used / worn when performing relevant tasks during this installation.

Personal Protective Equipment:-

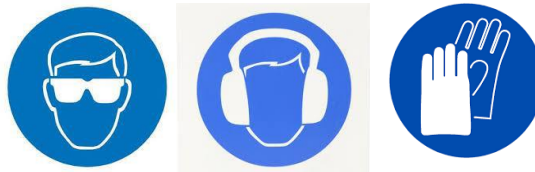

Torque Chart for Bolts

Bolt tensions	Dia. (mm)	Nm	ft.lbs	Dia. (inch)	Nm	ft.lbs
All bolt tensions are as follows unless otherwise specified.	5	5	4	1/4"	9	7
	6	9	7	5/16"	22	15
	8	22	16	3/8"	33	27
	10	44	32	7/16"	55	43
	12	77	57	1/2"	86	66
	14	121	90	-	-	-

PARTS LIST		
DESCRIPTION	QTY	PART No.
Snorkel Body	1	011MB00121Y
Intermediate Tube	1	011IP00121Y
Airbox Connector	1	011AC00121Y
Air Box Plug	1	
Door Pillar Bracket	1	F-6593
Outer guard Template	1	F-34663-T
Fitting instructions	1	F-34663
Hose Clamp (Black)	1	HC052B
Hose Clamp	1	HC052
011SAT0121Y		
AIR RAM	1	011AIR14B97T
011SATW00121Y		
WEDGETAIL	1	011AIRWT400

BOLT KIT	
DESCRIPTION	QTY
8G X 3/4 Stainless PK Screw	4
M8 X 1.25 X 30 S/S Stud	3
M8 S/S Mudguard Washer	4
M8 Nyloc Hex nut	3
M8 x 1.25 x 16 S/S Hex Head Screw	1
M8 S/S Spring Washer	1
M8 x 1.25 x 16 Button Head Screw (Black)	1
M8 Spring washer (Black)	1
M8 x 17 Flat washer (Black)	1
Nylon Plugs	2
Plastic Fender Clips	9
Mini Duck Bill Valve	1
8G X 3/4 Stitching Screw (Black)	1



FITTING INSTRUCTIONS

Product:

AIRTEC SNORKEL

Vehicle:

MY 22 FORD RANGER

Part No.

011SAT0121Y 011SATW0121Y



1. Position vehicle on a hoist (where possible) for access to the RHS inner guard area. A flat level concrete surface is also suitable if a hoist is not available.

Jack up the front of the vehicle to allow more room under the wheel arch, secure with chassis stands.

Remove the RHS front wheel for access (optional)

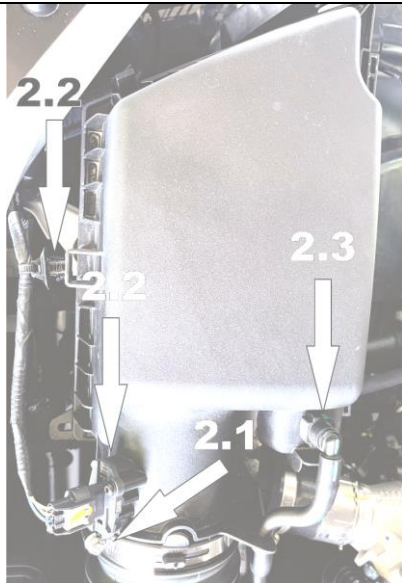

2. Loosen the hose clamp securing the intake hose to the airbox lid and disconnect. (2.1)

Cover the intake hose with a plastic bag or similar so no foreign matter can enter the engine.

Disconnect the sensor fitting (2.2) and the breather hose (2.3) from the airbox lid, then unclip the clamps on the airbox lid and remove and retain the airbox lid and air filter.

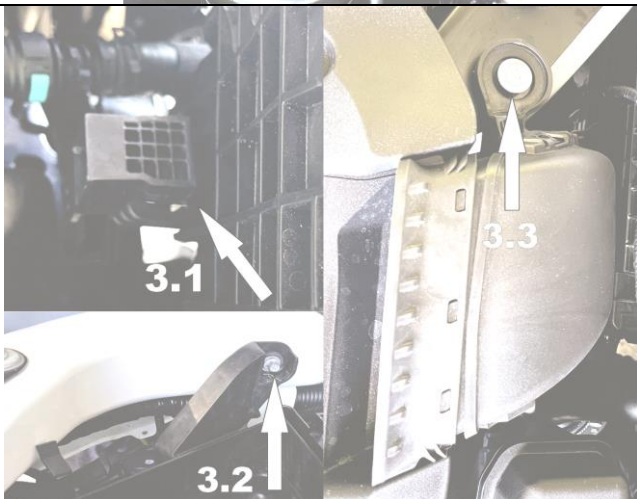

3. Remove and retain the plastic hose support bracket from the rear left hand side of the air box base (3.1)

Remove the 1 x hex bolt attaching the airbox base to the RHS fender support rail (3.2) and the 1 x torx screw attaching the OE air intake to the radiator support panel. (3.3). Remove the airbox base by gently lifting upwards. (the airbox base is attached to the vehicle by 2 plastic pins pushed into rubber feet). Set aside to be worked on in step 25.

If you buy from 4x4AT, we offer fitting services at an additional cost. Please contact us for more information.



FITTING INSTRUCTIONS

Product:

AIRTEC SNORKEL

Vehicle:

MY 22 FORD RANGER

Part No.

011SAT0121Y 011SATW0121Y



4. From under the RHS wheel arch remove and retain the 7 plastic screw clips attaching the mud flap.

From under the RHS wheel arch remove and retain the remaining 2 plastic screw clips, 2 x torx screws and 4 plastic attaching the flare.

Remove the wheel arch flare from the rear of the wheel arch forward carefully popping 9 x plastic clips attaching it to the fender (some clips may break new ones are supplied with the kit).

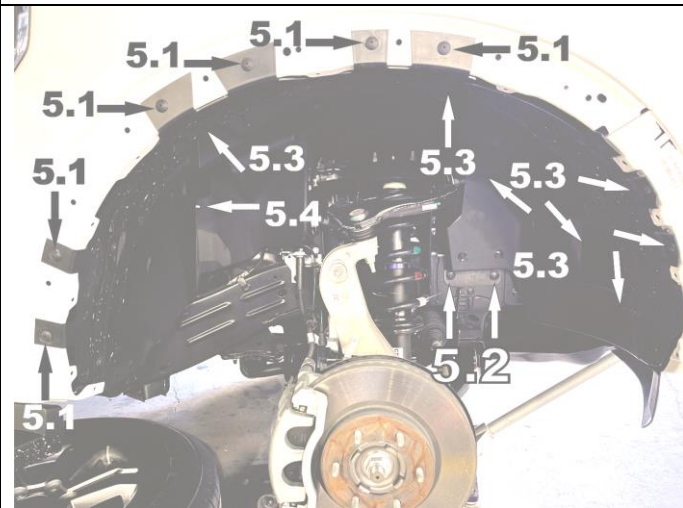

5. Remove and retain the 6 plastic screw clips attaching the plastic inner fender to the outside of the fender.(5.1)

From under the RHS wheel arch remove the 2 large christmas tree clips (5.2), 7 plastic screw clips (5.3) and 1 x hex nut (5.4) holding the plastic inner fender.

Remove and retain the plastic inner fender.

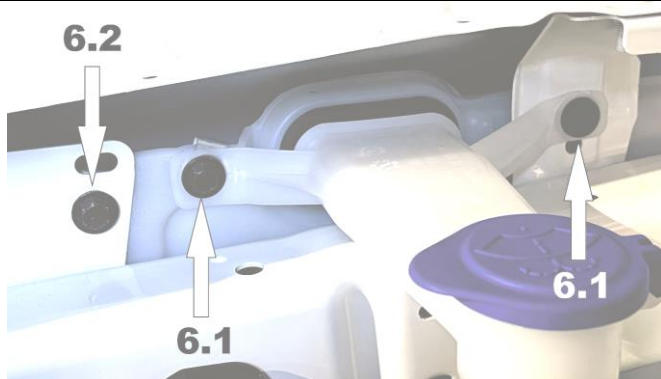

6. From inside the engine bay remove and retain the 2 bolts (6.1) holding the window washer filler neck and the 1 bolt (6.2) holding the front top of the window washer bottle.

Remove and retain the window washer filler neck.

If you buy from 4x4AT, we offer fitting services at an additional cost. Please contact us for more information.



FITTING INSTRUCTIONS

Product:

AIRTEC SNORKEL

Vehicle:

MY 22 FORD RANGER

Part No.

011SAT0121Y 011SATW0121Y

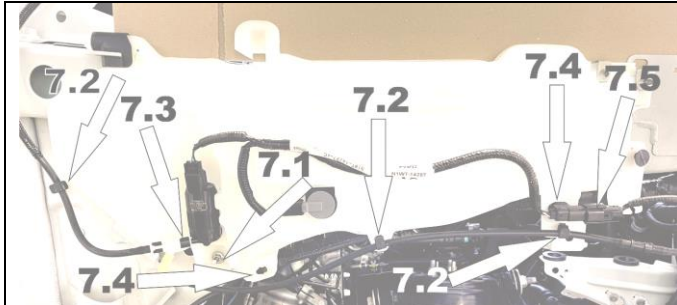

7. From under the RHS wheel arch remove and retain the hex nut (7.1) holding the bottom rear of the window washer bottle.

Unclip the 3 clips (7.2) attaching the window washer hose to the window washer bottle, and the 1 clip (7.3) attaching the hose to the window washer pump.

Unclip the 2 wiring harnesses (7.4) attached to the window washer bottle, then unplug the window washer pump harness (7.5).

Remove and retain the window washer bottle.



8. Cut out the supplied guard template and fit the template to the fender making sure it is aligned correctly.

Using a 3mm drill bit, drill a pilot hole in all locations.

Drill the 121mm hole in the correct position as per the template.

Drill the remaining 4 holes to 14mm



9. Remove all sharp edges from the holes then remove the template. Treat all raw/exposed edges with a rust preventative product or similar.

If you buy from 4x4AT, we offer fitting services at an additional cost. Please contact us for more information.



FITTING INSTRUCTIONS

Product:

AIRTEC SNORKEL

Vehicle:

MY 22 FORD RANGER

Part No.

011SAT0121Y 011SATW0121Y



10. **Positioning of the “A” pillar bracket on the vehicle:-** Using a protective tape, mask the RHS “A” pillar as indicated to prevent potential damage

The “A” pillar bracket should already be attached to the snorkel body – If not secure the “A” pillar bracket to the top of the snorkel body using the Black M8 button head screw, Black M8 spring washer and Black flat washer supplied.



11. Test fit the snorkel to the vehicle, be sure to hold the snorkel body firmly against the fender and position the top bracket on the “A” pillar.

Using the top bracket as a guide mark the 2 hole positions on the “A” pillar.

Remove the snorkel body from the vehicle



12. Lightly center punch the “A” pillar in the position of the 2 marked holes.

Using a 3mm drill bit – drill a pilot hole.

Important:- Drill through the **outer skin only** as some vehicles have critical components in this area of the “A” pillar.

13. Drill the 2 holes to a final size of 8mm, remove all sharp edges from the holes, Remove the protective tape and treat all raw/exposed edges with a rust preventative product or similar.

If you buy from 4x4AT, we offer fitting services at an additional cost. Please contact us for more information.



FITTING INSTRUCTIONS

Product:

AIRTEC SNORKEL

Vehicle:

MY 22 FORD RANGER

Part No.

011SAT0121Y 011SATW0121Y

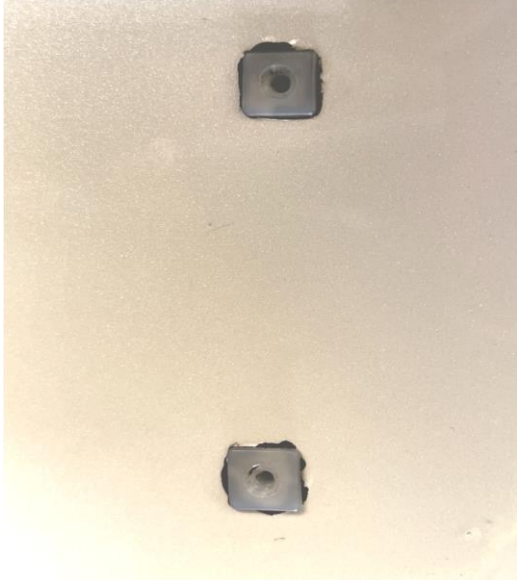

14. Apply a liberal amount of neutral cure silicone to the 2 holes in the "A" pillar.
15. Place the nylon plugs in the hole, using a soft face hammer gently tap in the nylon plugs until fully seated as shown.

Wipe off excess silicone.



16. Remove the "A" pillar bracket from the snorkel body and secure to the "A" pillar using 3/4" x 8G stainless steel PK screws supplied.

Note:- Torque the screws to a maximum of 7Nm by hand only.

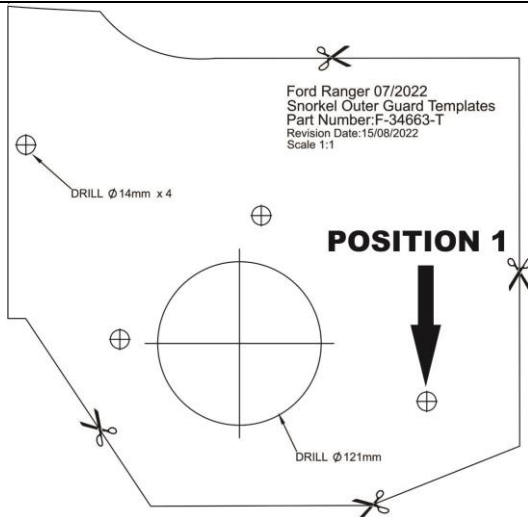

17. Fit the snorkel body to the vehicle and loosely secure the snorkel body to the A pillar bracket.

Do not tighten at this stage.

18. Loosely attach the snorkel body in position 1 with an M8x16 hex bolt, M8 spring washer and 5/16" x 1.1/4" flat washer.

Position 1 is the nutsert location closest to the front of the vehicle.

If you buy from 4x4AT, we offer fitting services at an additional cost. Please contact us for more information.



FITTING INSTRUCTIONS

Product:

AIRTEC SNORKEL

Vehicle:

MY 22 FORD RANGER

Part No.

011SAT0121Y 011SATW0121Y

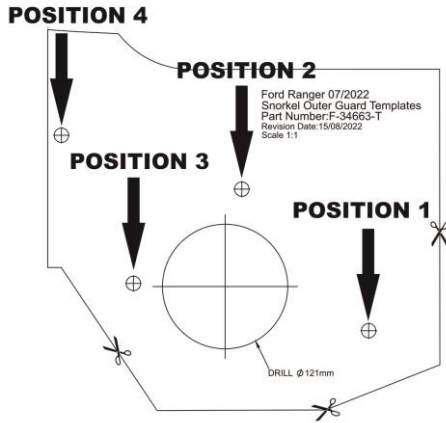

19. Loosely attach the snorkel in the positions 2, 3 and 4 with an M8 x 30mm stud, 5/16" x 1/4" flat washer and a M8 nyloc nuts.

20. Tighten the 1 x bolt and the 3 x nyloc nuts to the specified torque setting. **(Refer to page 2 of this instruction)**



21. From inside the airbox base unclip the OE air intake, then remove and discard it.

22. On the RHS outside of the airbox base there is an impression of an 89mm circle.

Using an 89mm hole saw cut a hole inside the above impression, Clean and deburr ensuring there is no lip inside the hole. **(22.1)**

In the bottom of the airbox base there is an impression of a circle, drill an 11mm hole in the centre of this impression, insert the duck bill drain valve into this 11mm hole. **(22.2)**

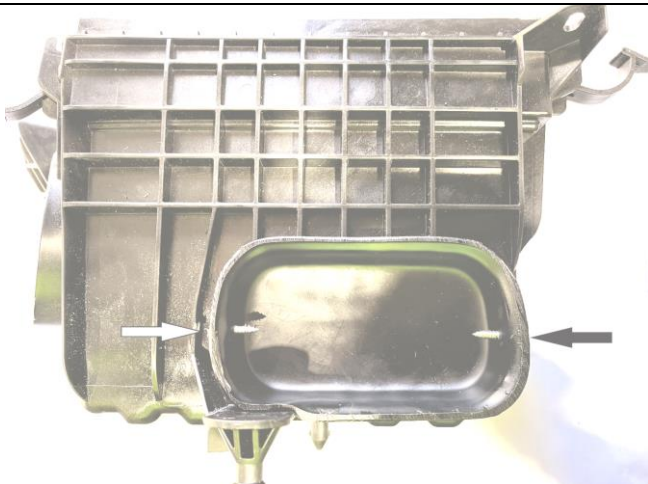

23. Apply a liberal amount of neutral cure silicone to the inside surface of the original airbox intake opening.

Clean the airbox plug and fit it in the original intake opening.

Secure in place with 2 x 3/4" x 8g stainless steel PK screws as pictured.

If you buy from 4x4AT, we offer fitting services at an additional cost. Please contact us for more information.



FITTING INSTRUCTIONS

Product:

AIRTEC SNORKEL

Vehicle:

MY 22 FORD RANGER

Part No.

011SAT0121Y 011SATW0121Y



24. Apply a liberal amount of neutral cure silicone to the inside surface of the snorkel end of the intermediate tube.

From under the RHS wheel arch connect the intermediate tube to the snorkel body spigot, ensure the snorkel body spigot is fully located into the intermediate tube.



25. Apply a liberal amount of neutral cure silicone to the inside surface of the airbox connector at the snorkel end.

Loosely place a HC052 hose clamp on the snorkel end of the airbox connector.

From under the RHS wheel arch connect the air box connector to the airbox end of the intermediate tube.

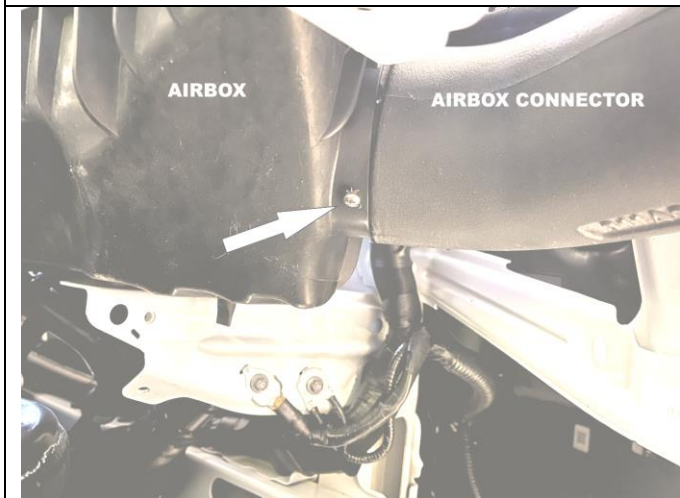

26. Apply a liberal amount of neutral cure silicone to the inside surface of the new hole cut in the airbox base in step 22.

Refit the airbox base to the vehicle in reverse sequence to step 3, ensuring that the airbox end of the airbox connector is fully located into the airbox base.

From the airbox secure the airbox connector into the airbox with 1 x 3/4" x 8g stainless steel PK screw as pictured.

Refit the airbox lid in reverse sequence to step 2.

If you buy from 4x4AT, we offer fitting services at an additional cost. Please contact us for more information.



FITTING INSTRUCTIONS

Product:

AIRTEC SNORKEL

Vehicle:

MY 22 FORD RANGER

Part No.

011SAT0121Y 011SATW0121Y



27. Refit the window washer bottle to the vehicle in reverse sequence to steps 7 and 8.

28. Refit the plastic inner fender, wheel arch flare and mudflap, in reverse sequence to steps 4, 5 and 6 using the original fixings as well as 9 new plastic clips to hold the wheel arch flare to the fender.

29. Refit the RHS wheel if previously removed.

30. Fit either the Air Ram top or Wedgetail top to the snorkel body, secure with the supplied hose clamp and tighten.

Do not use silicone on this joint.

WEDGETAIL



AIR RAM



If you buy from 4x4AT, we offer fitting services at an additional cost. Please contact us for more information.